

Characterizing the Nash Bargaining Solution Without Pareto-Optimality

Lensberg, Terje and William Thomson

Working Paper No. 136
May 1988

University of
Rochester

CHARACTERIZING THE NASH BARGAINING SOLUTION
WITHOUT PARETO-OPTIMALITY

by

Terje Lensberg*

and

William Thomson**

Working Paper No. 136

December 1986

Revised May 1988

*Norwegian School of Economics and Business Administration, Bergen, Norway.

**University of Rochester. Support from NSF under grant 8511136 is gratefully acknowledged. Thanks are also due to H. Moulin for his comments at an early stage of this research.

Characterizing the Nash Bargaining Solution
Without Pareto-Optimality

ABSTRACT

We consider the bargaining problem with a variable number of agents. Lensberg had previously characterized the Nash solution as the only solution to satisfy the following axioms: Pareto-Optimality, Symmetry, Scale Invariance, and Multilateral Stability. We show that the disagreement solution is the only additional solution to satisfy the restricted list of axioms obtained by dropping Pareto-Optimality.

**Characterizing the Nash Bargaining Solution
Without Pareto-Optimality**

1. Introduction

We propose a new axiomatic characterization of the Nash solution that does not involve any optimality axiom.

An *n*-person bargaining problem is a subset of \mathbb{R}_+^n each point of which gives the (von Neumann-Morgenstern) utilities achieved by *n* agents through the choice of some alternative open to them. Given a class of such problems, a *solution* on that class is a function associating with every problem of the class a point in it, its *solution outcome*, interpreted as the compromise reached by the agents, or recommended to them, depending on the context. Nash (1950)¹ proposed to search for solutions by specifying axioms that they should satisfy and he established the existence and the uniqueness of a solution, now called the *Nash solution*, satisfying the following four axioms;

Pareto-optimality: the solution outcome should be Pareto-dominated by no feasible point; *Symmetry*: if a problem is invariant under all exchanges of the names of the agents, the solution outcome should have equal coordinates; *Scale Invariance*: the solution should be independent of which elements in the class of equivalent von Neumann-Morgenstern utility scales representing the agents' preferences that are chosen to describe the problem; *Independence of Irrelevant Alternatives*: the elimination from a problem of a subset that does not contain its solution outcome yields a new problem whose solution outcome is the same.

¹Although Nash considered only the 2-person case, his result extends straightforwardly to the *n*-person case.

The independence axiom has been widely criticized. Indeed, its hypotheses allow for asymmetric contractions to which it is intuitively felt that the compromise should be allowed to respond.

Recently, Lensberg (1988) proposed a new characterization of the Nash solution which does not rely on this controversial axiom. Placing his analysis in the context of a variable number of agents (see Thomson (1983)), Lensberg showed the Nash solution to be the only solution to satisfy Pareto-Optimality, Anonymity, Scale Invariance, together with a condition of **Multilateral stability** stating a certain form of consistency of the solution across cardinalities.

Our objective is to elucidate the role played by the Pareto-optimality axiom in this theorem, and, at the same time, to better understand the role of the stability axiom.

Given that conflict situations in the real world are often solved at non-optimal points, it is indeed important to develop theories that allow for violations of Pareto-optimality. A number of recent axiomatizations have proceeded without this axiom and uncovered solutions that may help predict the sort of violations likely to occur. For instance, Dubey, Neyman and Weber (1981) have characterized non-optimal solutions to games in characteristic function form. These solutions generalize the Shapley-value. Non-optimal solutions to bargaining problems have also been characterized by Roth (1979) in the case of a fixed number of agents, and by Thomson (1982) in the case of a variable number of agents. These solutions generalize the egalitarian solution.

Although, as just noted, Nash's classic characterization of the Nash solution involves Pareto-optimality, this axiom plays essentially no role in

the theorem. Indeed, as shown by Roth (1977), there are only two solutions satisfying symmetry, scale invariance and independence of irrelevant alternatives: they are the Nash solution and the solution selecting the origin as solution outcome of all problems, which we will call the *disagreement solution*. Therefore, by requiring of the solution that there be at least one problem that is not solved at the origin, a very minor restriction indeed, only the Nash solution remains admissible. (Roth achieves the same purpose by imposing the condition that the solution always select a point that strictly dominates the origin.)

This result has strong implications. It shows that the other three axioms together have much more power than one might have thought a priori and that a search for non-optimal solutions would have to proceed in other directions.

We investigate here whether Lensberg's alternative characterization of the Nash solution is a more fruitful starting point in the search for interesting solutions that would fail to satisfy Pareto-optimality. The answer is negative. Indeed, the only additional solution made admissible by removing this requirement is also the disagreement solution. But this negative result has a positive side since it reveals the robustness of Lensberg's characterization.

2. Notation. Definitions. Axioms.

There is a set \mathcal{I} of *agents* indexed by the positive integers. \mathcal{P} is the class of finite subsets of \mathcal{I} containing at least two members, with generic elements P, Q, \dots . Given $P \in \mathcal{P}$, \mathcal{R}_+^P is the cartesian product of $|P|$ copies of

\mathcal{K}_+ , indexed by the members of P , and Σ^P is the class of all subsets S of \mathcal{K}_+^P that are convex, compact, comprehensive (for all $x, y \in \mathcal{K}_+^P$, if $x \in S$ and $y \leq x$, then $y \in S$)², and contain at least one x with $x > 0$. Σ^P is the class of bargaining problems, or simply *problems*, that the group P may face. A *solution* is a function F defined on $\Sigma \equiv \bigcup_{P \in \mathcal{P}} \Sigma^P$ which associates, for every $P \in \mathcal{P}$, and with every $S \in \Sigma^P$, a unique point of S , $F(S)$, called the *solution outcome of S* . This point is interpreted as the compromise recommended for S , or alternatively, as a prediction as to how the agents would solve S on their own. The restriction of F to a particular Σ^P is called the *component of F relative to P* .

We will consider solutions satisfying (some of) the following axioms.

Pareto-optimality (PO): For all $P \in \mathcal{P}$, for all $S \in \Sigma^P$, for all $y \in \mathcal{K}_+^P$, if $y \geq F(S)$, then $y \in S$.

Weak Pareto-optimality (WPO): For all $P \in \mathcal{P}$, for all $S \in \Sigma^P$, for all $y \in \mathcal{K}_+^P$, if $y > F(S)$, then $y \notin S$.

Let $PO(S)$ and $WPO(S)$ be the sets of Pareto-optimal and weakly Pareto-optimal points of S respectively.

Anonymity (AN): For all $P, P' \in \mathcal{P}$ with $|P| = |P'|$, for all one-to-one functions $\gamma: P \rightarrow P'$, for all $S \in \Sigma^P, S' \in \Sigma^{P'}$, if $S' = \gamma(S) \equiv \{x' \in \mathcal{K}_+^{P'} \mid \exists x \in S \text{ with } \forall i \in P, x'_{\gamma(i)} = x_i\}$, then for all $i \in P, F_{\gamma(i)}(S') = F_i(S)$.

Symmetry (SY): For all $P \in \mathcal{P}$, for all $S \in \Sigma^P$, if for all one-to-one functions $\gamma: P \rightarrow P, S = \gamma(S) (\equiv \{x' \in \mathcal{K}_+^P \mid \exists x \in S \text{ with } \forall i \in P, x'_{\gamma(i)} = x_i\})$, then for all $i, j \in P, F_i(S) = F_j(S)$.

²Vector inequalities: $y \geq x, y \leq x, y > x$.

Given $P \in \mathcal{P}$, Λ^P is the class of transformations $\lambda: \mathbb{R}^P \rightarrow \mathbb{R}^P$ for which there exists $a \in \mathbb{R}_{++}^P$ such that for all $x \in \mathbb{R}^P$ and for all $i \in P$, $\lambda_i(x) = a_i x_i$.

Scale Invariance (S.INV): For all $P \in \mathcal{P}$, for all $\lambda \in \Lambda^P$, for all $S \in \Sigma^P$, $F(\lambda(S)) = \lambda(F(S))$.

Homogeneity (HOM): For all $P \in \mathcal{P}$, for all $\lambda \in \Lambda^P$ with $\lambda_i = \lambda_j$, for all $i, j \in P$, for all $S \in \Sigma^P$, $F(\lambda(S)) = \lambda(F(S))$

Given $P, Q \in \mathcal{P}$ with $P \subset Q$, $T \in \Sigma^Q$ and $y \in T$, let $t_P^y(T) \equiv \{x \in \mathbb{R}^P \mid (x, y_{Q \setminus P}) \in T\}$. $t_P^y(T)$ is the *slice of T through y parallel to the coordinate subspace \mathbb{R}^P* .

Multilateral Stability (M.STAB): For all $P, Q \in \mathcal{P}$ with $P \subset Q$, for all $S \in \Sigma^P$, $T \in \Sigma^Q$, if $S = t_P^y(T)$, where $y = F(T)$, then $F(S) = y_P$.

Bilateral Stability (B.STAB): For all $P, Q \in \mathcal{P}$ with $P \subset Q$ and $|P| = 2$, for all $S \in \Sigma^P$, $T \in \Sigma^Q$, if $S = t_P^y(T)$, where $y = F(T)$, then $F(S) = y_P$.

Our final axiom is:

Continuity (CONT): For all $P \in \mathcal{P}$, for all sequences $\{S^k\}$ from Σ^P , for all $S \in \Sigma^P$, if $S^k \rightarrow S$ (in the Hausdorff topology), then $F(S^k) \rightarrow F(S)$.

Next, we define two solutions of interest. Given $P \in \mathcal{P}$ and $S \in \Sigma^P$, the **Nash solution** (1950) outcome of S , $N(S)$, is the unique maximizer of $\prod x_i$ for $x \in S$, and the **disagreement solution** outcome of S , $D(S)$, is the origin.

Other Notation. Given $Q \in \mathcal{P}$, $S^1, \dots, S^k \subset \mathbb{R}^Q$, $\text{cch}\{S^1, \dots, S^k\}$ is the smallest convex and comprehensive subset of \mathbb{R}^Q containing S^1, \dots, S^k . e_Q is the vector in \mathbb{R}^Q whose coordinates are all equal to one. Given $S \subset \mathbb{R}^Q$ and $i \in Q$, $a_i(S) \equiv \max\{x_i \mid x \in S\}$.

3. The Results

We start with a short summary of our results. We will need the following important definition.

Given $P \in \mathcal{P}$, $i \in P$, $x \in \mathcal{X}^P$ and $\lambda \in]0,1]$, the i^{th} λ -extension of x , denoted $\chi^i(\lambda, x)$, is the point $y \in \mathcal{X}^P$ such that $x_i = \lambda y_i$ and $x_j = y_j$ for all $j \in P$ with $j \neq i$.

First, we show that if a solution satisfies **AN**, **HOM** and **B.STAB**, then either it satisfies **PO**, or it is the disagreement solution, or there exists $\lambda \in]0,1[$ such that for all $P \in \mathcal{P}$ and for all $S \in \Sigma^P$, if x is the solution outcome of S , then for all $i \in P$, the $|P|$ λ -extensions of x all belong to the weak Pareto-optimal boundary of S .

Given $S \in \Sigma^P$, and $\lambda \in]0,1[$, let $N^\lambda(S)$ be the set of points whose $|P|$ λ -extensions all belong to $WPO(S)$. If $|P| = 2$, $N^\lambda(S)$ is always a singleton so that the necessary conditions lead to well-defined two-person component solutions. As λ increases from 0 to 1, the path of this point is a continuous curve which has the origin and the Nash solution outcome of S as end points. Therefore, this one parameter family of *Nash-like solutions*, N^λ , may be interpreted as modelling a progressive negotiation process leading to the Nash solution.

If $|P| \geq 3$, it remains true that $N^\lambda(S) \neq \emptyset$ for all $S \in \Sigma^P$. However, complications arise. Indeed, for every $\lambda \in]0,1[$ there exist some problems S for which $N^\lambda(S)$ is not a singleton. Are there single-valued selections from the *correspondence* N^λ that satisfy **CONT**? The answer is negative. This is somewhat disappointing since continuity certainly is a desirable property.

However, the property that is of most interest to us here is **M.STAB**. Are there single-valued selections that satisfy **M.STAB**? Again, the answer is negative. This dashes our hopes of finding interesting solutions satisfying **AN**, **HOM** and **M.STAB**.

But this negative result is what gives us our characterization of the Nash solution. Indeed, the only values of λ left are then $\lambda=0$ and $\lambda=1$. If $\lambda=0$, the disagreement solution obtains. If $\lambda=1$, **PO** holds and then Lensberg's result becomes applicable, when **HOM** is strengthened to **S.INV**, leading to the Nash solution. Again, by requiring that at least one problem be solved at a point different from the origin, only the Nash solution remains admissible. It will be convenient to extend the definition of the family N^λ of Nash-like solution correspondences to include the boundary cases $\lambda = 0$ and $\lambda = 1$. Formally, for all $P \in \mathcal{P}$ and all $S \in \Sigma^P$, we define

$$N^\lambda(S) \equiv \begin{bmatrix} \{0\} & \text{if } \lambda = 0 \\ \{x \in S \mid \forall i \in P, \chi^i(\lambda, x) \in WPO(S)\} & \text{if } \lambda \in]0, 1[\\ PO(S) & \text{if } \lambda = 1 \end{bmatrix}$$

We are now ready to present the details of the proof. Recall that our objective is to characterize all solutions satisfying **AN**, **S.INV** and **M.STAB**. As it turns out, we will be able to derive workable necessary conditions by using **HOM** instead of **S.INV** and **B.STAB** instead of **M.STAB**. The necessary conditions are what we develop first. Let then F be a solution satisfying **AN**, **HOM** and **B.STAB**. Our first result is based only on the first two of those axioms.

Lemma 1: There exists $\lambda \in [0,1]$ such that for all $P \in \mathcal{P}$, and for all $\alpha \in \mathcal{K}_{++}$,
 $F(\text{cch}\{\alpha e_p\}) = \lambda \alpha e_p$.

Proof: Let $P \equiv \{1,2\}$ and $S \equiv \text{cch}\{e_p\}$. By **SY** (implied by **AN**), it follows that $F(S) = \lambda e_p$ for some $\lambda \in [0,1]$. By **HOM**, for all $\alpha \in \mathcal{K}_{++}$, $F(\alpha S) = \lambda \alpha e_p$. The proof concludes by appealing to **AN**.

Q.E.D.

Lemma 2: For all $P \in \mathcal{P}$ with $|P| = 2$, for all $x \in \mathcal{K}_{++}^P$, $F(\text{cch}\{x\}) = \lambda x$, where λ is the parameter identified in Lemma 1.

Proof: The proof is illustrated in Figure 1. Let $P \equiv \{1,2\}$ and $S \equiv \text{cch}\{x\}$ where $x \in \mathcal{K}_{++}^P$. We introduce agent 3, and we set $Q \equiv \{1,2,3\}$ and $T \equiv \text{cch}\{(x_1, x_2, x_1)\}$. Note that $T \in \Sigma^Q$. Let $z \equiv F(T)$, $P^2 \equiv \{1,3\}$ and $S^2 \equiv t_{P^2}^z(T)$. S^2 is a square in \mathcal{K}^{P^2} of side x_1 . By Lemma 1, $F(S^2) = \lambda(x_1, x_1)$. Since by **B.STAB**, $z_{P^2} = F(S^2)$, we conclude that $z_1 = z_3 = \lambda x_1$. Also, $S = t_P^z(T)$ and by **B.STAB** again, we conclude that $z_1 = F_1(S) = \lambda x_1$.

Next, let $T \equiv \text{cch}\{(x_1, x_2, x_2)\}$. Note that $T \in \Sigma^Q$. Let $z \equiv F(T)$.

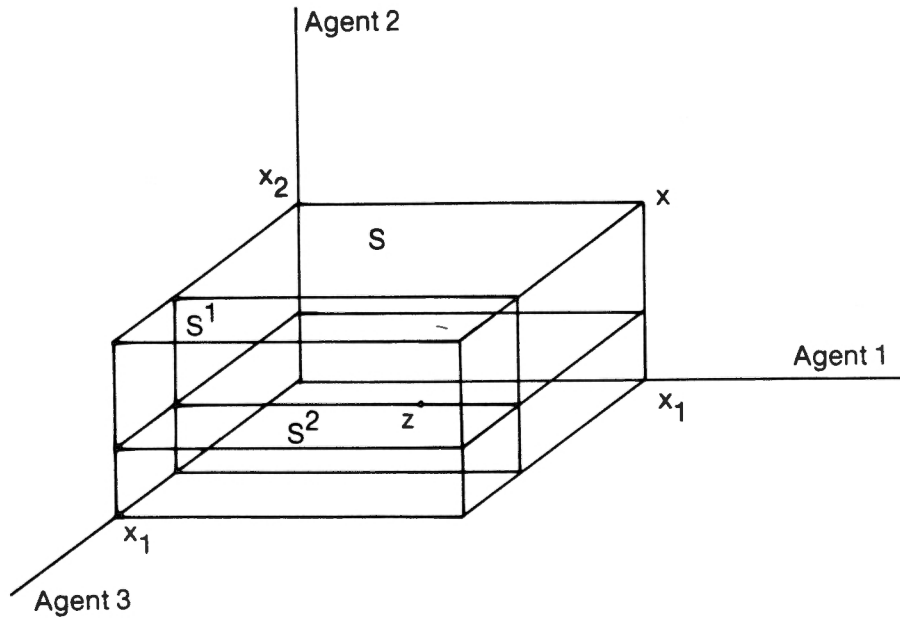

Figure 1

Set $P^1 \equiv \{2,3\}$ and $S^1 \equiv t_{P^1}^z(T)$. S^1 is a square in \mathfrak{P}^{P^1} of side x_2 . By Lemma 1, $F(S^1) = \lambda(x_2, x_2)$. A repetition of the argument above yields $z_2 = F_2(S) = \lambda x_2$.

Altogether, we have shown that $F(S) = \lambda(x_1, x_2) = \lambda x$.

Q.E.D.

Proposition 1: For all $P \in \mathcal{P}$ and for all $S \in \Sigma^P$, $F(S) \in N^\lambda(S)$, where λ is the parameter identified in Lemma 1.

Proof: We first show that the proposition holds for all $P \in \mathcal{P}$ with $|P| = 2$. The proof is illustrated in Figure 2. Let $P \equiv \{1,2\}$ and $S \in \Sigma^P$ be given. Let $Q \equiv \{1,2,3\}$ and $T \in \Sigma^Q$ be defined by $T \equiv \text{cch}\{S + \{ce_3\}\}$, where c is some arbitrary positive number. Let $z \equiv F(T)$ and $P^2 \equiv \{1,3\}$. Note that $t_{P^2}^z(T)$ is a rectangle, that is, there exists $\alpha \geq 0$ such that $t_{P^2}^z(T) = \text{cch}\{(\alpha, c)\}$.

Suppose first that $\lambda < 1$. We claim that $\alpha > 0$. Indeed, if $\alpha = 0$, note first that $z_2 = a_2(S) = a_2(T)$. Then, let $P^1 \equiv \{2,3\}$ and observe that $t_{P^1}^z(T) = \text{cch}\{(a_2(S), c)\} \in \Sigma^{P^1}$. By Lemma 2, $F(t_{P^1}^z(T)) = (a_2(S), c)\lambda$ and by **B.STAB**, $F(t_{P^1}^z(T)) = z_{P^1}$. Therefore, $F_2(t_{P^1}^z(T)) = z_2 = a_2(S)\lambda$. Since $\lambda < 1$, we obtain a contradiction with the previous equality $z_2 = a_2(S)$. Since $\alpha > 0$, then $t_{P^2}^z(T)$ is a non-degenerate rectangle and it follows by Lemma 2 that $F(t_{P^2}^z(T)) = (\alpha, c)\lambda$. Since $t_P^z(T) = S$, **B.STAB** then implies that $F_1(t_P^z(T)) = F_1(S) = \alpha\lambda$.

The same reasoning, applied to subproblems parallel to \mathcal{K}^{P^2} , yields that $F_2(S) = b\lambda$ for some $b > 0$ such that $t_{P^2}^z(T) = \text{cch}\{(b, c)\}$. Altogether, we have shown that if $x = F(S)$, then either $x = 0$ if $\lambda = 0$ or $\chi^1(\lambda, x) \in \text{WPO}(S)$ and $\chi^2(\lambda, x) \in \text{WPO}(S)$ if $\lambda \in]0, 1[$. If $\lambda = 1$, it follows by a similar argument that F satisfies PO on Σ^P whenever $|P| = 2$. Consequently, the proposition holds for all $P \in \mathcal{P}$ with $|P| = 2$.

Next, let $Q \in \mathcal{P}$ with $|Q| \geq 3$ and $T \in \Sigma^Q$ be given. If $\lambda \in [0, 1[$, it follows by **B.STAB** and the first part of the proof that $F(T) \in N^\lambda(T)$. If $\lambda = 1$, suppose by way of contradiction that $y \equiv F(T) \notin N^\lambda(T)$. Since $y \notin \text{PO}(T)$ and T contains a strictly positive vector, there exist $P \equiv \{i, j\} \subset Q$ and $x \in T$ such that $x \geq y$, $x_i > y_i$ and $x_p > 0$. Since $x_p > 0$, the problem $S \equiv t_P^y(T)$ is well defined, which by **B.STAB** implies that $F(S) = F_P(T) = y_p$. Since $|P| = 2$

then $F(S) \in PO(S)$, in contradiction with the fact that $x_p \geq y_p$.

Q.E.D.

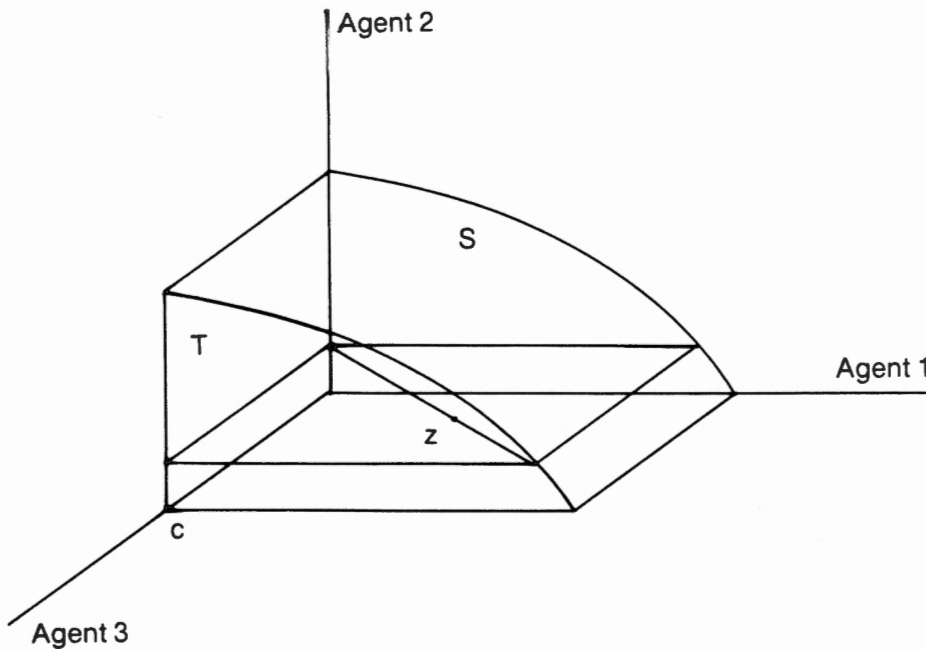

Figure 2

Having thus established a necessary condition for a solution F to satisfy **AN**, **HOM** and **B.STAB**, we must next show that F is well defined, i.e. that $F(S)$ exists and is unique for all S . We begin with the question of existence which, according to Proposition 1, must be dealt with by showing that the correspondence N^λ is nonempty-valued for all λ .

To this end, we introduce the following notation and terminology. Given $P \in \mathcal{P}$ and $S \in \Sigma^P$, let $v^S: \mathcal{X}_+^P \rightarrow \mathcal{X}$ be a continuous and strictly increasing function such that $v^S(x) \leq 0$ if and only if $x \in S$. (As an example, set $v^S(0) \equiv -1$, $v^S(x) \equiv 0$ if $x \in WPO(S)$ and v^S linear on each ray). Finally, given $\lambda \in]0, 1[$, let $V^{S,\lambda}: S \rightarrow \mathcal{X}^P$ be defined by $V_i^{S,\lambda}(x) \equiv v^S(x^i(\lambda, x))$ for each $i \in P$.

Note that $V^{S,\lambda}$ defines a continuous *vector field* on S such that $V^{S,\lambda}(x) = 0$ if and only if $x \in N^\lambda(S)$. Say that a vector field V on S *points out at* $x \in S$ if the point $x + V(x)$ is on or above some hyperplane of support of S at x . If V points out at every $x \in \partial S$, say that V *points out on* ∂S . Clearly, $V^{S,\lambda}$ points out on ∂S . Finally, for each $P \in \mathcal{P}$, let $\Sigma_{\text{diff}}^P \equiv \{S \in \Sigma^P \mid V^S \text{ can be chosen to be differentiable}\}$.

Proposition 2: For all $\lambda \in [0,1]$, the correspondence N^λ is nonempty-valued.

Proof: Let $P \in \mathcal{P}$ and $S \in \Sigma^P$ be given. If $\lambda = 0$ then $N^\lambda(S) = \{0\} \neq \emptyset$ and if $\lambda = 1$ then $N^\lambda(S) = PO(S) \neq \emptyset$. Suppose that $\lambda \in]0,1[$. Since $V^{S,\lambda}$ is a continuous vector field on S that points out on ∂S , there exists $x \in S$ such that $V^{S,\lambda}(x) = 0$ (Varian (1981)). Any such x is in $N^\lambda(S)$.

Q.E.D.

We next turn to the issue of uniqueness. This is easily dealt with if $\lambda = 0$ or $\lambda = 1$: Clearly, if $\lambda = 0$ then F must be the disagreement solution. If $\lambda = 1$ it follows directly from Lensberg's theorem that $F = N$ if *HOM* is strengthened to *S.INV*. In either case, there is a unique solution outcome to every problem and the necessary conditions are obviously sufficient. It remains to investigate the case of $\lambda \in]0,1[$. First, we show that in this case N^λ is single-valued on the family of two-person problems.

Proposition 3: Suppose $\lambda \in]0,1[$. The correspondence N^λ is single-valued on Σ^P for all $P \in \mathcal{P}$ with $|P| = 2$.

Proof: The argument is illustrated in Figure 3. Let ℓ^1 and ℓ^2 be the loci of the points $(\lambda x_1, x_2)$ and $(x_1, \lambda x_2)$ when x runs over $WPO(S)$. Proposition 2 guarantees that ℓ^1 and ℓ^2 intersect at some point x . We must show here that x is unique.

Suppose that ℓ^1 and ℓ^2 intersected more than once, at two points x and y , with $x \neq y$. Consider the two λ -extensions $x^1 \equiv \chi^1(\lambda, x)$ and $x^2 \equiv \chi^2(\lambda, x)$ of x and the two λ -extensions $y^1 \equiv \chi^1(\lambda, y)$ and $y^2 \equiv \chi^2(\lambda, y)$ of y . It is easy to check that neither one of x and y can weakly dominate the other. Without loss of generality we can assume that $y_1 > x_1$ and $y_2 < x_2$. Therefore x^1, x^2 and y^1, y^2 are two pairs of points of $WPO(S)$, a concave curve, satisfying $x_1^2 \geq y_1^2$ and $x_1^1 \geq y_1^1$, so that the slope of the segment $[x^2, x^1]$ is smaller than the slope of the segment $[y^2, y^1]$. Since the former is equal to the negative of the slope of the segment $[0, x]$ and the latter to the negative of the slope of the segment $[0, y]$, a contradiction results with the assumed relation between x and y .

Q.E.D.

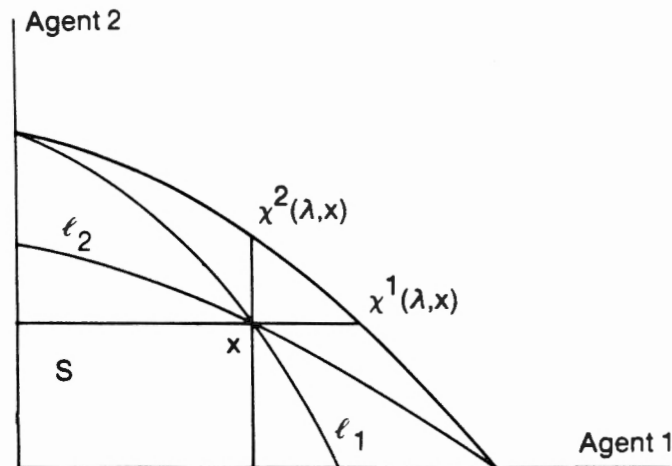

Figure 3

The issue of singlevaluedness of N^λ for problems of cardinality greater than 2 will be solved by means of an example S^0 involving a number of agents that depends on λ but in order to simplify notation, this dependence will not be indicated. We will also write $\chi_i(x)$ for $\chi_i(\lambda, x)$ Let n be the **smallest** integer n' such that

$$(1) \quad 1/\lambda^2 < n'.$$

(Note that $n=2$ for all $\lambda \in]\frac{1}{\sqrt{2}}, 1[$).

Let $P \equiv \{1, \dots, n+1\}$ and $a, b, c, d \in \mathbb{R}$ be defined by

$$a = (2/(n\lambda^2 + 1))^{1/2}$$

$$b = 1 + a\lambda(1-a)$$

$$c = (1+\lambda)/\lambda$$

$$d = (n\lambda+1)/\lambda$$

Then let $S^1 \equiv \{x \in \mathbb{R}_+^P \mid ax_1 + b \max_{i \neq 1} \{x_i\} \leq c\}$, $S^2 \equiv \{x \in \mathbb{R}_+^P \mid \sum_P x_i \leq d\}$ and

finally $S^0 \equiv S^1 \cap S^2$. S^0 is illustrated in Figure 4 for $\lambda = .8$ (which gives $n=2$, $a=0.94$, $b=1.05$, $c=2.25$ and $d=3.25$).

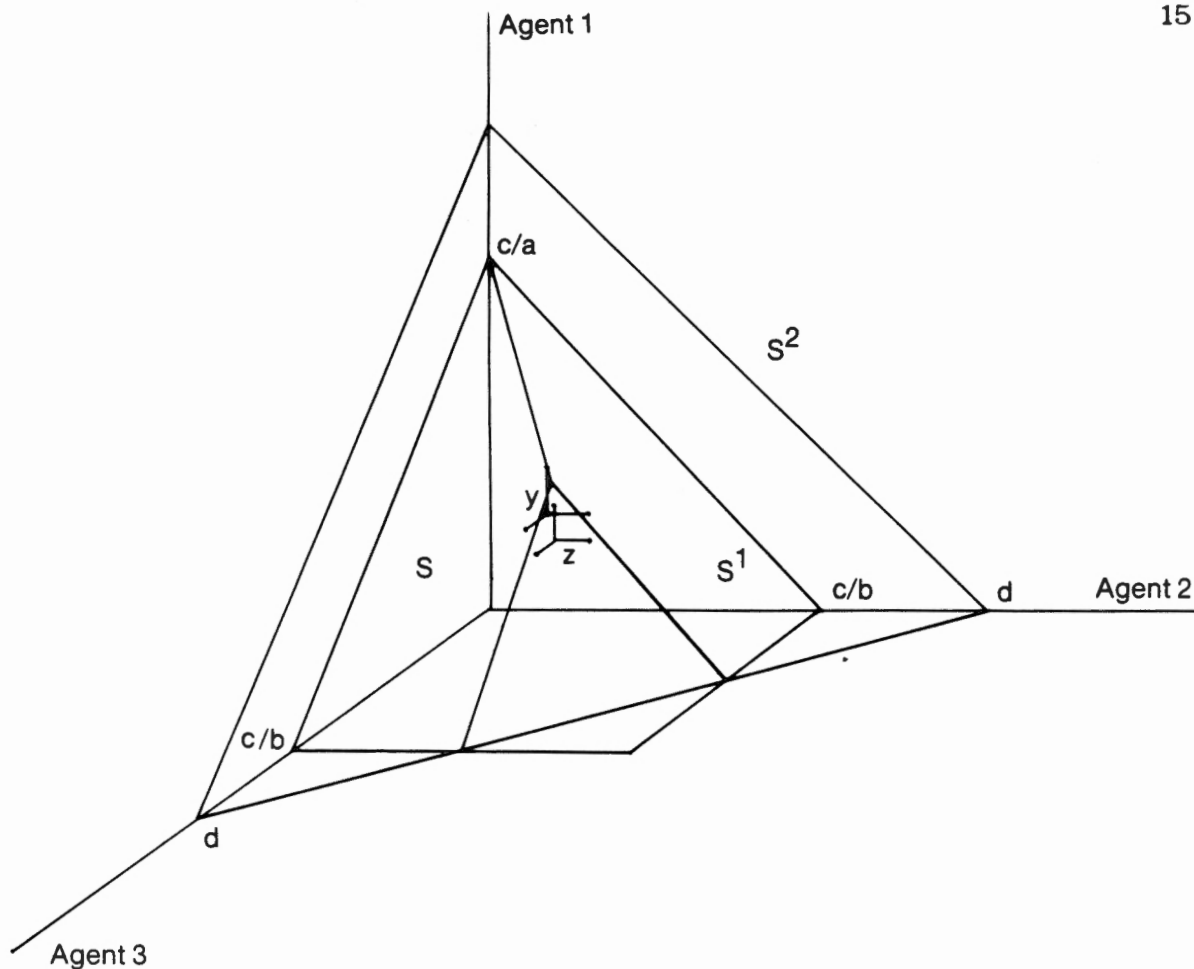

Figure 4

Proposition 4: For no $\lambda \in]0,1[$ is N^λ single-valued.³

Proof. Let $\lambda \in]0,1[$ be given and consider the problem S^0 defined above. It will be shown that $y \equiv (1/a, 1/b, \dots, 1/b)$ and $z \equiv e_p$, which are distinct, both belong to $N^\lambda(S^0)$.

First, it is shown that $\{y\} = N^\lambda(S^1)$. It is easily checked that if a problem S' is invariant under permutations involving a subgroup of agents,

³An example establishing this fact for $n = 3$ was also constructed by H. Moulin.

then all members of the subgroup receive the same amount at any $x \in N^\lambda(S')$. Since in S^1 , all agents $i \neq 1$ are interchangeable, if $x \in N^\lambda(S^1)$, then $x_i = x_j$ for all $i, j \in P \setminus 1$. In fact $x \in N^\lambda(S^1)$ if and only if, in addition, its first two coordinates solve the following system of equations:

$$\begin{cases} ax_1/\lambda + bx_2 = c \\ ax_1 + bx_2/\lambda = c \end{cases}$$

Since $\lambda \in]0,1[$, this system has a unique solution. It is $(x_1, x_2) = (1/a, 1/b)$, in the computation of which the fact that $c=(1+\lambda)/\lambda$ is used. Thus $\{y\} = N^\lambda(S^1)$.

Next, it is shown that $\{z\} = N^\lambda(S^2)$. Since S^2 is invariant under all permutations of agents, if $x \in N^\lambda(S^2)$, then $x_i = x_j$ for all $i \in P$. The common value of the x_i is given by solving

$$x_i/\lambda + nx_i = d,$$

and since $d = (n\lambda+1)/\lambda$, it follows that $x_i = 1$. Thus $\{z\} = N^\lambda(S^2)$.

To prove that in fact, $y, z \in N^\lambda(S^0)$, it now suffices to show that for all $i \in P$, $\chi^i(z)$ lies below $WPO(S^1)$ and that $\chi^i(y)$ lies below $WPO(S^2)$.

Appealing again to the symmetries of S^1 and S^2 , it is enough to check this for $i=1,2$. This gives

$$\begin{array}{ll} a/\lambda + b < c & : \quad \chi^1(z) \text{ is below } WPO(S^1) \\ a + b/\lambda < c & : \quad \chi^2(z) \text{ is below } WPO(S^1) \\ 1/a\lambda + n/b < d & : \quad \chi^1(y) \text{ is below } WPO(S^2) \\ 1/a + 1/b\lambda + (n-1)/b < d & : \quad \chi^2(y) \text{ is below } WPO(S^2). \end{array}$$

By (1) it follows that $a < 1$ and $b > 1$. Therefore the four inequalities will hold if the middle two do. The second holds since $a < 1$, given the definitions of b and c . Using the definitions of b and d , the third inequality can be written as

$$A \equiv (1-a)(a^2 n \lambda^2 - 1 - a \lambda(1-a)) > 0$$

and since

$$\begin{aligned} A &> (1-a)(a^2 n \lambda^2 - 1 - a(1-a)) , && \text{because } \lambda < 1 \\ &> (1-a)(a^2 n \lambda^2 - 2 + a^2) , && \text{because } a < 1 \\ &= (1-a)(a^2(n \lambda^2 + 1) - 2) \\ &= 0 , && \text{by definition of } a, \end{aligned}$$

we are done.

Q.E.D.

Remark 1: It could be shown by a similar argument that $N^\lambda(S^0)$ actually contains a third point x . This point is such that $\chi^1(x) \in \text{PO}(S^2)$ and $\chi^i(x) \in \text{WPO}(S^1)$ for all $i \in P \setminus 1$.

Remark 2: It will be useful later to note that y and z are *isolated* members of $N^\lambda(S^0)$ since $\chi^i(y)$ and $\chi^i(z)$ in fact lie *strictly* below $\text{WPO}(S^2)$ and $\text{WPO}(S^1)$ respectively. This is because the inequalities above are strict.

Remark 3: The problem S^1 used in the proof of Proposition 4 can be used to show that it is not in general true that $N^\lambda(S)$, as a set, converges to $N(S)$ as $\lambda \rightarrow 1$. Moreover, $N^\lambda(S)$ may be a singleton for all λ and still not converge to $N(S)$ as $\lambda \rightarrow 1$.

Let $n=2$ and S be as S^1 above with $a=b=c=1$. Then $x \in N^\lambda(S)$ if and only if

$$x_1/\lambda + x_2 = 1 \quad \text{and}$$

$$x_1 + x_2/\lambda = 1.$$

This system of equations gives $N^\lambda(S) = \{(\mathcal{N}(1+\lambda))e_p\}$. As $\lambda \rightarrow 1$, $N^\lambda(S) \rightarrow \{e_p/2\}$ while $N(S) = (1/3, 2/3, 2/3)$.

The reason for this lack of convergence is that the set $B^N(S)$ of points x of S such that $x_{P'} = N(t_{P'}^x, (S))$ for all $P' \subset P$ with $|P'| = 2$ is not a singleton. Indeed, $B^N(S) = [e_P/2, (0,1,1)]$. All we can say in general is that $N^\lambda(S)$ converges to (a subset of) $B^N(S)$. Of course, if $S \in \Sigma_{\text{dif}}^P$, then $B^N(S)$ is a singleton (see e.g. Harsanyi (1977)), and convergence of $N^\lambda(S)$ to $N(S)$ will occur. However, even if $S \in \Sigma_{\text{dif}}^P$, $N^\lambda(S)$ may not be a singleton. This can be seen by simply smoothing the example of Proposition 4.

Although N^λ is not single-valued, there is still the hope that some continuous single-valued selections from N^λ exist. The next Proposition dashes this hope.

Proposition 5: Let $\lambda \in]0,1[$ be given. Then there is no solution F satisfying *CONT* such that $F(S) \in N^\lambda(S)$ for all $P \in \mathcal{P}$ and for all $S \in \Sigma^P$.

Proof: Let $\lambda \in]0,1[$ and F be a single-valued subcorrespondence of N^λ . Also, let n, P, S^0, S^2, S, y and z be as in the proof of Proposition 4 and let $S \equiv S^0$. Since $y \neq z$, either $F(S) \neq y$ or $F(S) \neq z$.

Suppose first that (i) $F(S) \neq y$, and for all $\alpha \geq 1$, let $S^\alpha \equiv S^1 \cap \alpha S^2$. Observe that (ii) y is an isolated member of $N^\lambda(S^\alpha)$ for all $\alpha \geq 1$. (Remark 2). Moreover, $S^\alpha = S^1$ for all α sufficiently large. Since $N^\lambda(S^1) = \{y\}$ and $F \subset N^\lambda$, it follows that (iii) $F(S^1) = y$. From (i), (ii) and (iii), we conclude that F does not satisfy *CONT*.

Supposing next that $F(S) \neq z$, we establish the desired conclusion by a similar argument, applied to $T^\alpha \equiv \alpha S^1 \cap S^2$.

Q.E.D.

From this negative result and Proposition 1, we get the following positive one:

Theorem 1: A solution satisfies **AN**, **S.INV**, **B.STAB** and **CONT** if and only if it is either the disagreement solution or the Nash solution.

Theorem 1 shows that the axiom of Pareto-optimality plays a very modest role in Lensberg's (1988) characterization of the Nash solution, the only role of this axiom being to rule out one single alternative solution, the disagreement solution. A variant of that characterization result uses **PO**, **AN**, **S.INV** and **M.STAB** instead of **PO**, **AN**, **S.INV**, **CONT** and **B.STAB**. There is therefore the question of whether a similar variant to Theorem 1 above is obtained if **B.STAB** and **CONT** are replaced by **M.STAB**. Proposition 6 below answers that question in the affirmative, stating that single-valued selections from N^λ are not multilaterally stable for any $\lambda \in]0,1[$ ⁴

Proposition 6: Let $\lambda \in]0,1[$ be given. Then there is no solution F satisfying **M.STAB** such that $F(S) \in N^\lambda(S)$ for all $P \in \mathcal{P}$ and for all $S \in \Sigma^P$.

Proof: Let $\lambda \in]0,1[$ and F be a single-valued subcorrespondence of N^λ . Also, let n , P , a , b , c and d be as in the proof of Proposition 4. Finally, given $\rho > 1$, let $w^\rho: \mathfrak{R}_+^P \rightarrow \mathfrak{R}$ be defined by

$$w^\rho(x) \equiv x_1 - [(c/a - (b/a)(\sum_{P \setminus 1} x_i^\rho)^{1/\rho})^{-\rho} + (d - \sum_{P \setminus 1} x_i)^{-\rho}]^{-1/\rho},$$

⁴Note, however, that by definition of N^λ for $\lambda \in]0,1[$, all single-valued selections from N^λ are bilaterally stable.

The function w^ρ is strictly increasing, convex and differentiable for all $\rho > 1$. Therefore $S^\rho \equiv \{x \in \mathcal{X}_+^P \mid w^\rho(x) \leq 0\} \in \Sigma_{\text{dif}}^P$ for all $\rho > 1$. Also, for each $x \in \mathcal{X}^P$, $w^\rho(x) \rightarrow w^\infty(x)$ as $\rho \rightarrow \infty$, where

$$w^\infty(x) \equiv x_1 - \min[c/a - b/a \max_{P \setminus 1}\{x_i\}, d - \sum_{P \setminus 1} x_i],$$

and therefore, $S^\rho \rightarrow S^0$. By Proposition 4, $N^\lambda(S^0)$ contains two distinct points y and z . These points are topologically stable as they are the unique solutions to systems of linear equations. Consequently, for sufficiently large ρ , $N^\lambda(S^\rho)$ contains two distinct points x^1 and x^2 . For such a ρ , let $w \equiv w^\rho$ and $S \equiv S^\rho$.

The proof will consist in showing that if F satisfies **M.STAB**, then $F(S) = x^1$ but also $F(S) = x^2$, a contradiction to the assumption that F is a function. This conclusion will be obtained by constructing a $|Q|$ -person problem T , where $Q \supset P$, such that $N^\lambda(T)$ is a singleton y satisfying for each $k = 1, 2$, $y_p = x^k$ and $t_p^y(T) = S$, two statements which in view of **M.STAB**, imply $F(S) = x^k$.

Choose $k = 1$ or $k = 2$. Note that, for all λ , there exists a positive integer m such that

$$(m-1)n/\lambda - mn > 0.$$

(If $\lambda < 1/2$, the inequality is satisfied by $m = 2$). Let such an m be given.

Let $P^1 \equiv P \setminus 1 = \{2, \dots, n+1\}$, and for all $j = 2, \dots, m$, let $P^j \equiv \{2 + (j-1)n, \dots, n+1 + (j-1)n\}$ and $Q \equiv \{1\} \cup \bigcup_{j=1}^m P^j$. Let $\gamma: \mathcal{X}_+^n \rightarrow \mathcal{X}$ and $v^T: \mathcal{X}_+^Q \rightarrow \mathcal{X}$ be defined by

$\gamma(x) \equiv w(\alpha, x) - \alpha$ where $x = (x_2, \dots, x_{n+1})$, and

$$v^T(y) \equiv y_1 + \sum_{j=1}^m \gamma(y_{p_j}) - (m-1)\gamma(y_{p_1}^k).$$

Finally, let T (See Figure 5) be defined by

$$T \equiv \{x \in \mathfrak{R}_+^Q \mid v^T(x) \leq 0\}.$$

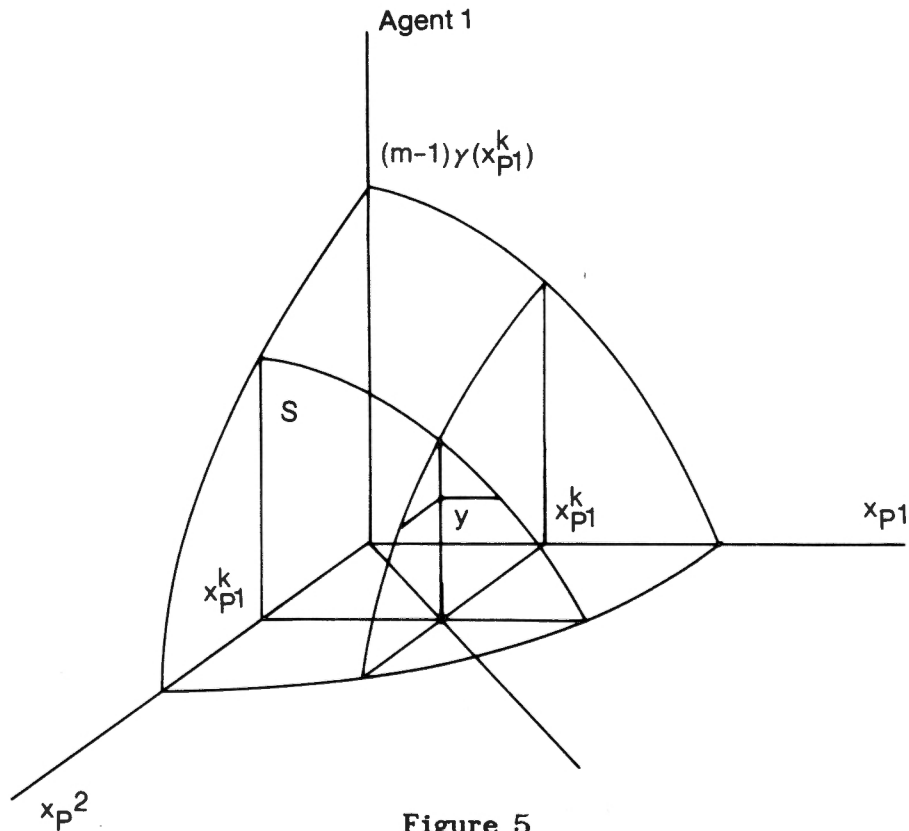

Figure 5

Note that T is symmetric in $x_{Q \setminus 1}$ since γ is symmetric in $x_{Q \setminus 1}$. Also, for $y \in \mathfrak{R}_+^Q$ defined by $y \equiv (x_1^k, x_{p_1}^k, \dots, x_{p_1}^k)$, we have $t_P^y(T) = t_{p_j}^y(T) = S$ for all $j = 1, \dots, m$, and since $x^k \in N^\lambda(S)$, it follows that $y \in N^\lambda(T)$.

We now claim that $N^\lambda(T) = \{y\}$. To prove this, let $V^T: T \rightarrow \mathfrak{R}^Q$ be defined by $V_i^T(x) = v^T(x^i(x))$ for all $i \in Q$. Then $x \in N^\lambda(T)$ if and only if $V^T(x) = 0$.

Let now $T^d \equiv T \cap \{x \in \mathbb{R}^Q \mid x_i = x_j \text{ for all } i, j \in Q \setminus 1\}$. $N^\lambda(T) \subset T^d$ since T is symmetric in the coordinates $x_{Q \setminus 1}$, and N^λ , as a correspondence, satisfies **AN**. Thus, all the zeros of V^T belong to T^d . Also, for all $x \in T^d$, the vector $V^T(x) + x$ lies in the hyperplane in \mathbb{R}_+^Q spanned by T^d . Letting $P' = \{1, 2\}$ and $T_{P'}^d$, be the projection of T^d on $\mathbb{R}_+^{P'}$, this implies that the function $V: T_{P'}^d \rightarrow \mathbb{R}^{P'}$ defined by $V(x_1, x_2) \equiv V_{P'}^T(x_1, x_2, \dots, x_2)$ is a vector field on $T_{P'}^d$, such that for all $x \in T$, $V(x_1, x_2) = 0$ if and only if $V^T(x) = 0$. Moreover, V is differentiable and points out on the boundary of $T_{P'}^d$, since V^T has these properties on T .

We now show that the determinant of the Jacobian J of V is positive for all $x \in T_{P'}^d$. Then, by the Poincaré-Hopf index theorem (see e.g. Varian (1981)), V , and hence, V^T , has only one zero. Since $V(y_{P'}) = 0$, by the fact that $V^T(y) = 0$, this will establish that $N^\lambda(T) = \{y\}$.

V is now written as

$$V_1(x_1, x_2) = x_1/\lambda + m\gamma(x_2, \dots, x_2) - K$$

$$V_2(x_1, x_2) = x_1 + \gamma(x_2/\lambda, x_2, \dots, x_2) + (m-1)\gamma(x_2, \dots, x_2) - K$$

where $K \equiv (m-1)\gamma(x_{P'}^k)$. Therefore

$$J = \begin{bmatrix} 1/\lambda & m \sum_{i=1}^n \gamma_i(x_2, \dots, x_2) \\ 1 & \gamma_1(x_2/\lambda, x_2, \dots, x_2)(1/\lambda) + \sum_{i=2}^n \gamma_i(x_2/\lambda, x_2, \dots, x_2) \\ & + (m-1) \sum_{i=1}^n \gamma_i(x_2, \dots, x_2) \end{bmatrix}$$

where γ_i is the partial derivative of γ with respect to its i^{th} argument. Since γ is symmetric and strictly increasing, $\gamma_i(x_2, \dots, x_2) = \alpha$ for some $\alpha > 0$ and for all $i = 1, \dots, n$. Ignoring the first two positive terms of J_{22} and dividing the second column by α , it follows that $\det J > 0$ since $(m-1)n/\lambda - mn > 0$.

Q.E.D.

From this our main result follows.

Theorem 2 : A solution satisfies **AN**, **S.INV**, and **M.STAB** if and only if it is either the disagreement solution or the Nash solution.

4. *One Commodity Division Problems.*

In this section, it is shown that the restriction of the correspondence N^λ to the subclass of Σ of problems that are obtained from the division of a **single** commodity between agents whose utility functions satisfy standard assumptions, is single-valued and therefore constitutes a well defined solution on that class.

First, the class is formally defined. Given $P \in \mathcal{P}$, let (i) U^P be the set of lists $(u_i)_{i \in P}$ where for each $i \in P$, $u_i: \mathcal{X}_+ \rightarrow \mathcal{X}_+$ is **agent i 's utility function**, and (ii) $\Omega \in \mathcal{X}_{++}$ be a social **endowment**. It is assumed that for each $i \in P$, u_i is strictly increasing, concave, differentiable and satisfies $u_i(0) = 0$ and $u_i(\Omega) > 0$. Let $S(u, \Omega) \equiv \{x \in \mathcal{X}_+^P \mid \exists \omega \in \mathcal{X}_+^P \text{ with } \sum_P \omega_i \leq \Omega \text{ and } \forall i \in P, u_i(\omega_i) = x_i\}$. Note that $S(u, \Omega) \in \Sigma^P$. Also, since, for all $\alpha > 0$, $S(\hat{u}, \Omega/\alpha) = S(u, \Omega)$, where each \hat{u}_i is defined by $\hat{u}_i(\omega_i/\alpha) = u_i(\omega_i)$, there is no loss of generality

in taking $\Omega = 1$. Let then Σ^{1P} , where the superscript 1 is a reference to the fact that there is a unique commodity, be the class of problems $S(u) \equiv S(u,1)$. Finally, let $\Sigma^1 \equiv \bigcup_{P \in \mathcal{P}} \Sigma^{1P}$. Of course, if $|P| = 1$, then $\Sigma^{1P} = \Sigma^P$, but, if $|P| > 1$, Σ^{1P} is a proper subset of Σ^P . It is therefore conceivable that solutions behave better on Σ^1 than on Σ . This turns out to be the case for N^λ .

Theorem 2: For all $\lambda \in [0,1[$, for all $P \in \mathcal{P}$, N^λ is single-valued on Σ^{1P} .

Proof: Let $\lambda \in [0,1[$ be given. If $\lambda = 0$, the proof is trivial, so let us assume that $\lambda > 0$. Let $P \in \mathcal{P}$, $u \in U^P$ be given and $S \equiv S(u)$.

By our assumptions on the u_i , each u_i has an inverse f_i which is strictly increasing, differentiable and convex. S can then alternatively be described as

$$S \equiv \{x \in \mathbb{R}_+^P \mid \sum_{i \in P} f_i(x_i) \leq 1\}.$$

In the notation of Section 3, $x \in N^\lambda(S)$ if and only if $V_i^S(x) \equiv f_i(x_i/\lambda) + \sum_{j \in P \setminus i} f_j(x_j) - 1 = 0$ for all $i \in P$.

By differentiability of the f_i , it follows that the vector field V^S is smooth. To show that it vanishes at one point only, it suffices to show that its jacobian J is positive for all $x \in S$. J is given by

$$J = \begin{bmatrix} (1/\lambda)f'_1(x_1/\lambda) & f'_2(x_2) & \dots & f'_n(x_n) \\ f'_1(x_1) & (1/\lambda)f'_2(x_2/\lambda) & \dots & f'_n(x_n) \\ \cdot & & \dots & \\ \cdot & & \dots & \\ \cdot & & \dots & \\ f'_1(x_1) & f'_2(x_2) & \dots & (1/\lambda)f'_n(x_n/\lambda) \end{bmatrix}$$

For each $i \in P$, $f'_i > 0$, therefore, $a_i \equiv (1/\lambda)f'_i(x_i/\lambda)/f'_i(x_i)$ is well-defined. Since in addition $\lambda < 1$ and f_i is convex, then $a_i > 1$.

To compute the sign of J , for each $i \in P$, multiply column i by $1/f'_i(x_i) > 0$ and subtract the first row from all other rows. Then for each $i \in P$, $i \neq 1$,

multiply column i by the well defined quantity $\frac{a_1-1}{a_i-1}$ and add the sum to column

1. This yields the following matrix J' with $\text{sign } |J'| = \text{sign } |J|$.

$$J' \equiv \begin{bmatrix} a_1 + \frac{a_1-1}{\sum_{i \neq 1} a_i-1} & (a_1-1)/(a_2-1) & (a_1-1)/(a_3-1) & \dots & (a_1-1)/(a_n-1) \\ 0 & a_1-1 & 0 & \dots & 0 \\ 0 & 0 & a_1-1 & \dots & 0 \\ \cdot & \cdot & \cdot & \dots & \cdot \\ \cdot & \cdot & \cdot & \dots & \cdot \\ \cdot & \cdot & \cdot & \dots & \cdot \\ 0 & 0 & 0 & \dots & a_1-1 \end{bmatrix}$$

Since $\det J' > 0$, we are done.

Q.E.D.

References

- Dubey, P., A. Neyman and R. Weber, "Value Theory Without Efficiency," *Mathematics of Operations Research* 6 (1981), 122-128.
- Harsanyi, J.C. *Rational Behavior and Bargaining Equilibrium in Games and Social Situations*, Cambridge, University Press (1977).
- Lensberg, T., "The Stability of the Nash Solution," to appear in the *Journal of Economic Theory* (1988).
- Nash, J. F., "The Bargaining Problem," *Econometrica* 181 (1950), 155-162.
- Roth, A.E., "Individual Rationality and Nash's Solution to the Bargaining Problem," *Mathematics of Operations Research* 2 (1977), 64-65.
- _____, "Proportional Solutions to the Bargaining Problem," *Econometrica* 47 (1979), 775-778.
- Thomson, W., "The Fair Division of a Fixed Supply Among a Growing Population," *Mathematics of Operations Research* 8 (1983), 319-326.
- _____, "Truncated Egalitarian Solutions," *Social Choice and Welfare* 1 (1984), 25-32.
- Varian, H., "Dynamical Systems With Applications to Economics," in *Handbook of Mathematical Economics*, (K. Arrow and M. Intriligator, eds.) North-Holland, 1 (1981), 93-109.

Rochester Center for Economic Research
University of Rochester
Department of Economics
Rochester, NY 14627

1987-88 DISCUSSION PAPERS

- WP#68 RECURSIVE UTILITY AND OPTIMAL CAPITAL ACCUMULATION, I: EXISTENCE,
by Robert A. Becker, John H. Boyd III, and Bom Yong Sung, January
1987
- WP#69 MONEY AND MARKET INCOMPLETENESS IN OVERLAPPING-GENERATIONS MODELS,
by Marianne Baxter, January 1987
- WP#70 GROWTH BASED ON INCREASING RETURNS DUE TO SPECIALIZATION
by Paul M. Romer, January 1987
- WP#71 WHY A STUBBORN CONSERVATIVE WOULD RUN A DEFICIT: POLICY WITH
TIME-INCONSISTENT PREFERENCES
by Torsten Persson and Lars E.O. Svensson, January 1987
- WP#72 ON THE CONTINUUM APPROACH OF SPATIAL AND SOME LOCAL PUBLIC GOODS OR
PRODUCT DIFFERENTIATION MODELS
by Marcus Berliant and Thijs ten Raa, January 1987
- WP#73 THE QUIT-LAYOFF DISTINCTION: GROWTH EFFECTS
by Kenneth J. McLaughlin, February 1987
- WP#74 SOCIAL SECURITY, LIQUIDITY, AND EARLY RETIREMENT
by James A. Kahn, March 1987
- WP#75 THE PRODUCT CYCLE HYPOTHESIS AND THE HECKSCHER-OHLIN-SAMUELSON THEORY
OF INTERNATIONAL TRADE
by Sugata Marjit, April 1987
- WP#76 NOTIONS OF EQUAL OPPORTUNITIES
by William Thomson, April 1987
- WP#77 BARGAINING PROBLEMS WITH UNCERTAIN DISAGREEMENT POINTS
by Youngsub Chun and William Thomson, April 1987
- WP#78 THE ECONOMICS OF RISING STARS
by Glenn M. MacDonald, April 1987
- WP#79 STOCHASTIC TRENDS AND ECONOMIC FLUCTUATIONS
by Robert King, Charles Plosser, James Stock, and Mark Watson,
April 1987
- WP#80 INTEREST RATE SMOOTHING AND PRICE LEVEL TREND-STATIONARITY
by Marvin Goodfriend, April 1987
- WP#81 THE EQUILIBRIUM APPROACH TO EXCHANGE RATES
by Alan C. Stockman, revised, April 1987

- WP#82 INTEREST-RATE SMOOTHING
by Robert J. Barro, May 1987
- WP#83 CYCLICAL PRICING OF DURABLE LUXURIES
by Mark Bills, May 1987
- WP#84 EQUILIBRIUM IN COOPERATIVE GAMES OF POLICY FORMULATION
by Thomas F. Cooley and Bruce D. Smith, May 1987
- WP#85 RENT SHARING AND TURNOVER IN A MODEL WITH EFFICIENCY UNITS OF HUMAN CAPITAL
by Kenneth J. McLaughlin, revised, May 1987
- WP#86 THE CYCLICALITY OF LABOR TURNOVER: A JOINT WEALTH MAXIMIZING HYPOTHESIS
by Kenneth J. McLaughlin, revised, May 1987
- WP#87 CAN EVERYONE BENEFIT FROM GROWTH? THREE DIFFICULTIES
by Herve' Moulin and William Thomson, May 1987
- WP#88 TRADE IN RISKY ASSETS
by Lars E.O. Svensson, May 1987
- WP#89 RATIONAL EXPECTATIONS MODELS WITH CENSORED VARIABLES
by Marianne Baxter, June 1987
- WP#90 EMPIRICAL EXAMINATIONS OF THE INFORMATION SETS OF ECONOMIC AGENTS
by Nils Gottfries and Torsten Persson, June 1987
- WP#91 DO WAGES VARY IN CITIES? AN EMPIRICAL STUDY OF URBAN LABOR MARKETS
by Eric A. Hanushek, June 1987
- WP#92 ASPECTS OF TOURNAMENT MODELS: A SURVEY
by Kenneth J. McLaughlin, July 1987
- WP#93 ON MODELLING THE NATURAL RATE OF UNEMPLOYMENT WITH INDIVISIBLE LABOR
by Jeremy Greenwood and Gregory W. Huffman
- WP#94 TWENTY YEARS AFTER: ECONOMETRICS, 1966-1986
by Adrian Pagan, August 1987
- WP#95 ON WELFARE THEORY AND URBAN ECONOMICS
by Marcus Berliant, Yorgos Y. Papageorgiou and Ping Wang,
August 1987
- WP#96 ENDOGENOUS FINANCIAL STRUCTURE IN AN ECONOMY WITH PRIVATE INFORMATION
by James Kahn, August 1987
- WP#97 THE TRADE-OFF BETWEEN CHILD QUANTITY AND QUALITY: SOME EMPIRICAL EVIDENCE
by Eric Hanushek, September 1987

- WP#98 SUPPLY AND EQUILIBRIUM IN AN ECONOMY WITH LAND AND PRODUCTION
by Marcus Berliant and Hou-Wen Jeng, September 1987
- WP#99 AXIOMS CONCERNING UNCERTAIN DISAGREEMENT POINTS FOR 2-PERSON
BARGAINING PROBLEMS
by Youngsub Chun, September 1987
- WP#100 MONEY AND INFLATION IN THE AMERICAN COLONIES: FURTHER EVIDENCE ON
THE FAILURE OF THE QUANTITY THEORY
by Bruce Smith, October 1987
- WP#101 BANK PANICS, SUSPENSIONS, AND GEOGRAPHY: SOME NOTES ON THE
"CONTAGION OF FEAR" IN BANKING
by Bruce Smith, October 1987
- WP#102 LEGAL RESTRICTIONS, "SUNSPOTS", AND CYCLES
by Bruce Smith, October 1987
- WP#103 THE QUIT-LAYOFF DISTINCTION IN A JOINT WEALTH MAXIMIZING APPROACH TO
LABOR TURNOVER
by Kenneth McLaughlin, October 1987
- WP#104 ON THE INCONSISTENCY OF THE MLE IN CERTAIN HETEROSKEDASTIC REGRESSION
MODELS
by Adrian Pagan and H. Sabau, October 1987
- WP#105 RECURRENT ADVERTISING
by Ignatius J. Horstmann and Glenn M. MacDonald, October 1987
- WP#106 PREDICTIVE EFFICIENCY FOR SIMPLE NONLINEAR MODELS
by Thomas F. Cooley, William R. Parke and Siddhartha Chib,
October 1987
- WP#107 CREDIBILITY OF MACROECONOMIC POLICY: AN INTRODUCTION AND A BROAD
SURVEY
by Torsten Persson, November 1987
- WP#108 SOCIAL CONTRACTS AS ASSETS: A POSSIBLE SOLUTION TO THE
TIME-CONSISTENCY PROBLEM
by Laurence Kotlikoff, Torsten Persson and Lars E. O. Svensson,
November 1987
- WP#109 EXCHANGE RATE VARIABILITY AND ASSET TRADE
by Torsten Persson and Lars E. O. Svensson, November 1987
- WP#110 MICROFOUNDATIONS OF INDIVISIBLE LABOR
by Vittorio Grilli and Richard Rogerson, November 1987
- WP#111 FISCAL POLICIES AND THE DOLLAR/POUND EXCHANGE RATE: 1870-1984
by Vittorio Grilli, November 1987
- WP#112 INFLATION AND STOCK RETURNS WITH COMPLETE MARKETS
by Thomas Cooley and Jon Sonstelie, November 1987

- WP#113 THE ECONOMETRIC ANALYSIS OF MODELS WITH RISK TERMS
by Adrian Pagan and Aman Ullah, December 1987
- WP#114 PROGRAM TARGETING OPTIONS AND THE ELDERLY
by Eric Hanushek and Roberton Williams, December 1987
- WP#115 BARGAINING SOLUTIONS AND STABILITY OF GROUPS
by Youngsub Chun and William Thomson, December 1987
- WP#116 MONOTONIC ALLOCATION MECHANISMS
by William Thomson, December 1987
- WP#117 MONOTONIC ALLOCATION MECHANISMS IN ECONOMIES WITH PUBLIC GOODS
by William Thomson, December 1987
- WP#118 ADVERSE SELECTION, AGGREGATE UNCERTAINTY, AND THE ROLE FOR MUTUAL
INSURANCE COMPANIES
by Bruce D. Smith and Michael J. Stutzer, February 1988
- WP#119 INTEREST ON RESERVES AND SUNSPOT EQUILIBRIA: FRIEDMAN'S PROPOSAL
RECONSIDERED
by Bruce D. Smith, February 1988
- WP#120 INTERNATIONAL FINANCIAL INTERMEDIATION AND AGGREGATE FLUCTUATIONS
UNDER ALTERNATIVE EXCHANGE RATE REGIMES
by Jeremy Greenwood and Stephen D. Williamson, February 1988
- WP#121 FINANCIAL DEREGULATION, MONETARY POLICY, AND CENTRAL BANKING
by Marvin Goodfriend and Robert G. King, February 1988
- WP#122 BANK RUNS IN OPEN ECONOMIES AND THE INTERNATIONAL TRANSMISSION OF
PANICS
by Peter M. Garber and Vittorio U. Grilli, March 1988
- WP#123 CAPITAL ACCUMULATION IN THE THEORY OF LONG RUN GROWTH
by Paul M. Romer, March 1988
- WP#124 FINANCIAL INTERMEDIATION AND ENDOGENOUS GROWTH
by Valerie R. Bencivenga and Bruce D. Smith, March 1988
- WP#125 UNEMPLOYMENT, THE VARIABILITY OF HOURS, AND THE PERSISTENCE OF
"DISTURBANCES": A PRIVATE INFORMATION APPROACH
by Bruce D. Smith, March 1988
- WP#126 WHAT CAN BE DONE WITH BAD SCHOOL PERFORMANCE DATA?
by Eric Hanushek and Lori Taylor, March 1988
- WP#127 EQUILIBRIUM MARKETING STRATEGIES: IS THERE ADVERTISING, IN TRUTH?
by Ignatius Horstmann and Glenn MacDonald, revised, March 1988
- WP#128 REAL EXCHANGE RATE VARIABILITY UNDER PEGGED AND FLOATING NOMINAL
EXCHANGE RATE SYSTEMS: AN EQUILIBRIUM THEORY
by Alan C. Stockman, April 1988

- WP#129 POST-SAMPLE PREDICTION TESTS FOR GENERALIZED METHOD OF MOMENT ESTIMATORS
by Dennis Hoffman and Adrian Pagan, April 1988
- WP#130 GOVERNMENT SPENDING IN A SIMPLE MODEL OF ENDOGENOUS GROWTH
by Robert J. Barro, May 1988
- WP#131 FINANCIAL DEVELOPMENT, GROWTH, AND THE DISTRIBUTION OF INCOME
by Jeremy Greenwood and Boyan Jovanovic, May 1988
- WP#132 EMPLOYMENT AND HOURS OVER THE BUSINESS CYCLE
by Jang-Ok Cho and Thomas F. Cooley, May 1988
- WP#133 A REFINEMENT AND EXTENSION OF THE NO-ENVY CONCEPT
by Dimitrios Diamantaras and William Thomson, May 1988
- WP#134 NASH SOLUTION AND UNCERTAIN DISAGREEMENT POINTS
by Youngsub Chun and William Thomson, May 1988
- WP#135 NON-PARAMETRIC ESTIMATION AND THE RISK PREMIUM
by Adrian Pagan and Y. Hong, May 1988
- WP#136 CHARACTERIZING THE NASH BARGAINING SOLUTION WITHOUT PARETO-OPTIMALITY
by Terje Lensberg and William Thomson, May 1988

To order copies of the above papers complete the attached invoice and return to Christine Massaro, W. Allen Wallis Institute of Political Economy, RCER, 109B Harkness Hall, University of Rochester, Rochester, NY 14627. Three (3) papers per year will be provided free of charge as requested below. Each additional paper will require a \$5.00 service fee which must be enclosed with your order. For your convenience an invoice is provided below in order that you may request payment from your institution as necessary. Please make your check payable to the **Rochester Center for Economic Research**. Checks must be drawn from a U.S. bank and in U.S. dollars.

W. Allen Wallis Institute for Political Economy

Rochester Center for Economic Research, Working Paper Series

OFFICIAL INVOICE

Requestor's Name _____

Requestor's Address _____

Please send me the following papers free of charge (**Limit: 3 free per year**).

WP# _____ WP# _____ WP# _____

I understand there is a \$5.00 fee for each additional paper. Enclosed is my check or money order in the amount of \$_____. Please send me the following papers.

WP# _____ WP# _____ WP# _____

WP# _____ WP# _____ WP# _____

WP# _____ WP# _____ WP# _____

WP# _____ WP# _____ WP# _____